

NEW MOTORIZATION VIA SOLAR PANELS

- Manual or electric crank for opening and closing
- Easy to anchor thanks to a foldable adapter
- Easy exchangeable cover
- Windproof up to speeds of 37 mph, provided proper anchoring exists
- Vandalism safe with cladding design

Sizes

4x4m / 5x5m / 6x6m

Ø 4m / Ø 5m / Ø 6m

up to / bis zu

16 x 16 m



TULIP UMBRELLA TYPE E



TULIP UMBRELLA

The MDT tulip umbrella is constantly developed so that it can be freely designed. Whether alone as a unique design, artistically arranged in groups, or as a special means of presentation, this umbrella helps create new notions of freedom when it comes to recreational and outdoor areas. Available in a multitude of colors and individual prints, the Tulip umbrella enriches cultural and private events when combined with atmospheric lighting. Different aroma/scent diffusers are available for different food and beauty events. Rain flows down the mast and plexi-glas and can be routed either into or onto the ground, depending on the location and customer preferences.

- Automatically unfolds and closes
- Rain drain



TYPE E
TULIP
UMBRELLA

TULIP UMBRELLA
TYPE E



FRAME

Rectangular umbrella struts made of aluminum, 40x20 x2 -- 50x20x3 mm, round aluminum mast measuring 100x5 mm in diameter, 80x3 mm aluminum telescope, double mast with water drainage, top plate and crown plate made with aluminum U profiles for housing struts, screwed together parts, powder-coated frame (polyester powder ca. 80 μ).

- White RAL 9010
- other RAL colors on request

MECHANICS

Gearbox and spindle stored in center pole, umbrella opened/closed with hand crank or electric motor.

COVER

MDT-tex® 260 FR
(100% polyester dual-sided acrylate coating).
Weight ca. 260 g/m², water column pressure over 700 mm, flame retardant according to California T19. CERF Categoria 1, DIN 4102: B1

MDT-tex® 300
(100% acrylic fabric).
Weight ca. 300 g/m², water column pressure over 350 mm

Precontraint fabric
(100% polyester fabric, both sides with high gloss finish)
PVC coating, mass ca. 480 g/m²



Round



Square



Top



Struts



Crank

ANCHORINGS



Frame base



Ground tube



Ground tube foldable



Steel plate stand

ACCESSORIES



Protection sleeve



LED Lighting

similar picture

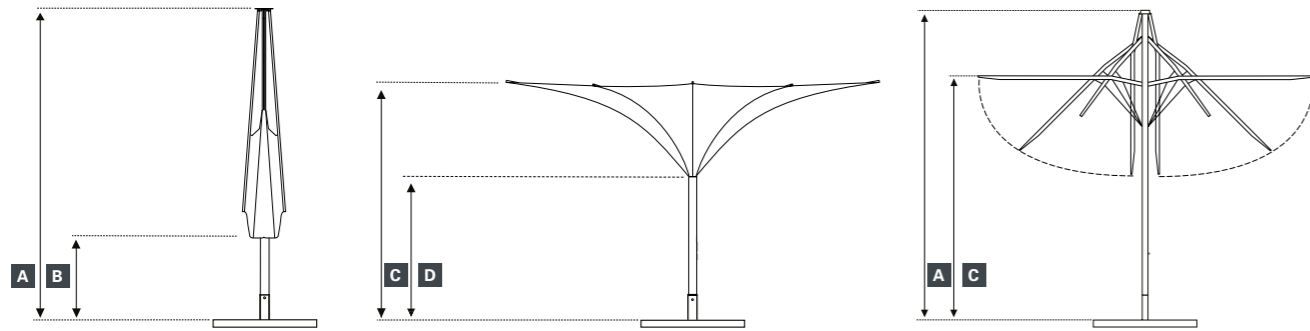

DIMENSIONS ARE IN METERS
*all measurements are rounded

	4x4	5x5	6x6	Ø4	Ø5	Ø6
MASS						
Umbrella with packaging (kg)	80	86,5	120	78	81	86
Umbrella without packaging (kg)	65	81,5	110	63	66	71
Frame (kg)	60	65	102	50	55	70
Cover (kg)	5	6,5	8	5	6	7

CLOSED UMBRELLA

A Closed height (cm)	435	435	490	435	435	470
B Distance from spokes to ground (cm)	160	91	85	245	195	180

OPENED UMBRELLA

C Opened height (cm)	335	335	390	335	335	370
D High up to the hopper (cm)	215	215	250	215	215	250

PACKAGING DIMENSIONS

Total length (cm)	435	435	470	435	435	470
Dimensions of cardboard packaging (cm)	40x40x360	40x40x360	45x45x360	40x40x360	40x40x360	45x45x360
Length of mast extruding from box (cm)	0	0	110	0	0	110

ACCESSORIES

Foldable adapter Article No.	Type 100 06757	Type 100 06757	Type 150 05775	Type 100 06757	Type 100 06757	Type 150 05775
Frame base 400 kg Article No.	Type 100/516 01684	Type 100/516 01684	-	Type 100/516 01684	Type 100/516 01684	-
Inground tube with water drain incl. folda. adapter Article No.	Type 100 E 02462-D	Type 100 E 02462-D	Type 150 E 12576	Type 100 E 02462-D	Type 100 E 02462-D	Type 150 E 12576
Protection sleeve size Article No.	XL 06673	XL 06673	XXL 00676	XL 06673	XL 06673	XL 06673

all dimensions + weights given are approximate

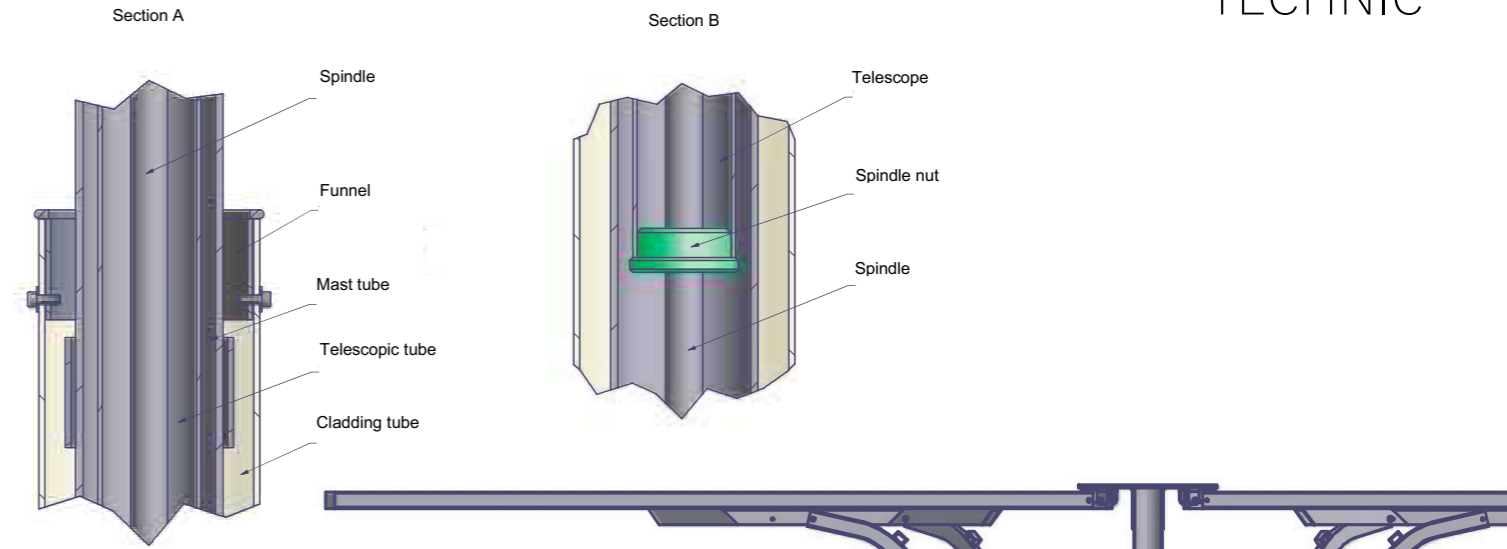

MATERIALS, PAINTS

MDT-tex®-FR 260 POLYESTER

For all dimensions.
For all types of umbrellas.

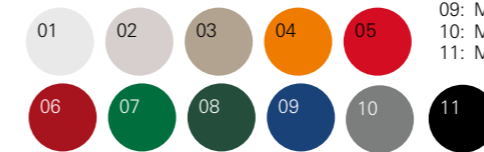

- 01: M 00-FR white
- 02: M 61-FR silver
- 03: M 21-FR beige
- 04: M 11-FR yellow
- 05: M 31-FR red
- 06: M 35-FR bordeaux
- 07: M 41-FR green
- 08: M 42-FR dark green
- 09: M 52-FR navy blue
- 10: M 81-FR anthracite
- 11: M 91-FR black

OPTIONAL

MDT-tex® 300 ACRYL

For all dimensions.
For all types of umbrellas.

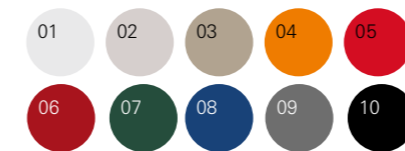

- 01: M 00-A white
- 02: M 21-A beige
- 03: M 22-A dark beige
- 04: M 11-A yellow
- 05: M 31-A red
- 06: M 35-A bordeaux
- 07: M 42-A dark green
- 08: M 52-A navy blue
- 09: M 81-A anthracite
- 10: M 91-A black

PVC 480 Polyester
Für alle Dimensionen.
Für alle Schirmtypen.

For all dimensions.
For all types of umbrellas.

01

01: M 00-P white-beige

Special colours on request.

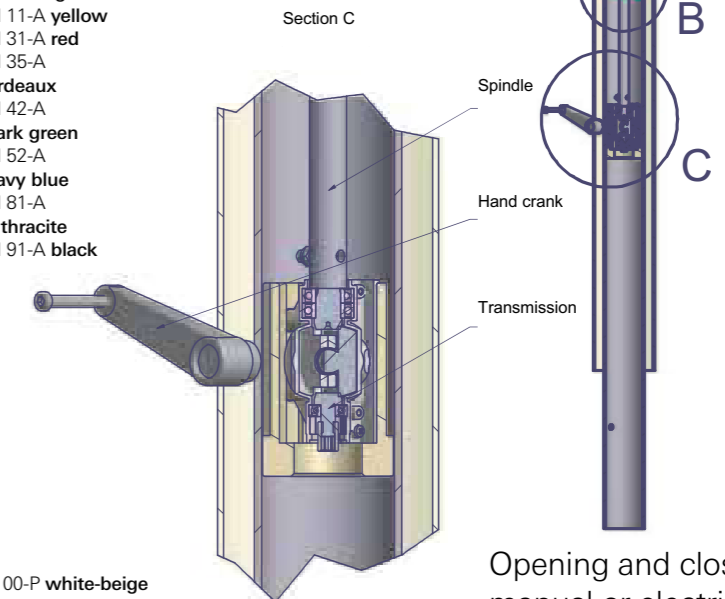

Opening and closing with manual or electric crank